



HEATING MANIFOLD & FIXTURE CART

For brazing and soldering machines

Do you have a brazing or soldering operation that joins multiple part numbers? Need a way to keep track of interchangeable tooling and heat manifolds between part runs?

Get organized with a heat manifold and fixture cart from Fusion. The triangular-shaped unit permits manifolds to be secured on two sides with fixtures stored on a reinforced, wire mesh base. Storage capacity is (8) manifolds for Fusion Braze Mate Machines and (4) manifolds for Fusion Rotary Index Machines.

Fully portable with locking casters, the cart is built with slotted aluminum frame and has pull handles on both sides. (56"H x 40"W x 42"D)

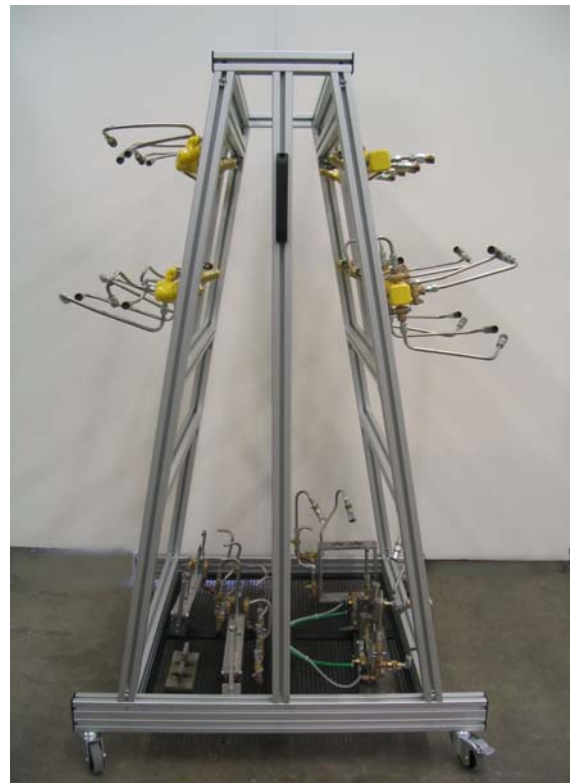
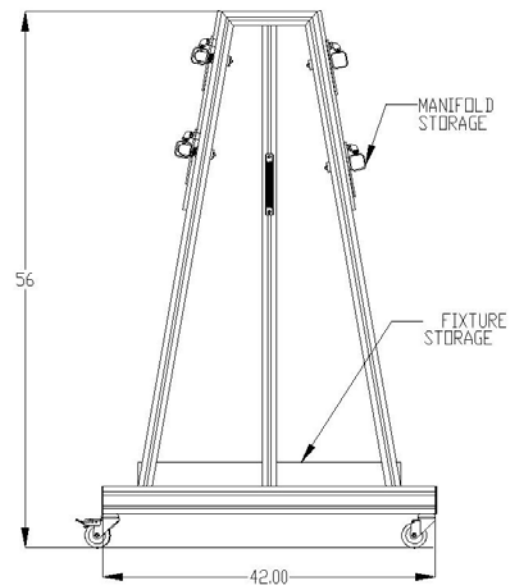

FUSION INCORPORATED

4658 E. 355th St., Willoughby, OH 44094
 Phone 1-800-626-9501 • (440) 946-3300
 Fax (440) 942-9083 • e-mail: info@fusion-inc.com
 Web: www.fusion-inc.com