

Fusion Model 615 Precision Digital Dispenser Instruction Manual

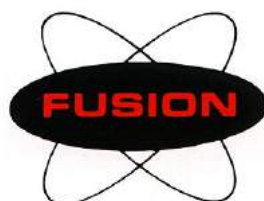

Fusion Incorporated
4658 E. 355th Street
Willoughby, OH 44094
Phone: 440-946-3300
www.fusion-inc.com
info@fusion-inc.com

Table of Contents

General	1
Standard Specification	1
Working Controls	1
Air & Electrical Setup	2
Installation	2
Operation.....	3
How to Use the Vacuum Control	3
Tips on Dispensing	3
Selecting the Correct Tip Size.....	4
What Can I Dispense?	5
Limited Warranty.....	5

General

The Fusion 615 Precision Dispenser can be used in many industries including electronics, aviation, automotive, food, medicine, chemistry, cosmetic, packing, craftwork, etc. It can be used for dispensing Fusion pastes as dots and/or stripes. It can also dispense other types of materials like adhesives and greases.

Standard Specification

Time Display: LED

Dispensing Time: 0.001 Sec -9.999 Sec

Air Input: 50-100 PSI

Repeatability Tolerance: $\pm 0.1\%$

Min Volume: 0.005ml

Max Speed: 600 Dispenses/Minute

Input Voltage: 110V $\pm 10\%$ 60Hz

Power Consumption: 30W

Weight: 3Kg

Working Controls

The Fusion 615 applicator has the following features:

Adjustable air pressure, vacuum control, programmable timer, LED display, and power switch.

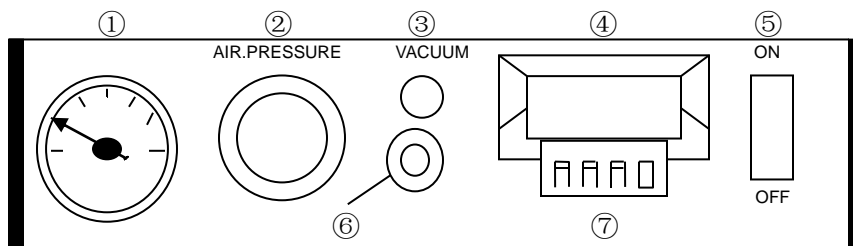

- ① Pressure gauge ② Pressure Control ③ VACUUM control ④ Time Display
⑤ Power switch ⑥ Output plug ⑦ Interval Timer Adjustment

AIR & ELECTRICAL SETUP

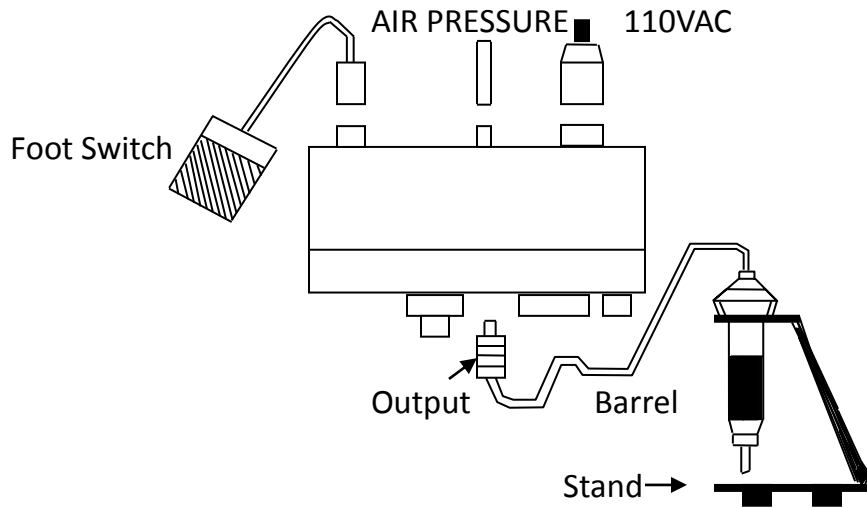

INSTALLATION

1. Connect the dispenser to plant air. A minimum of 50 PSI compressed air from a ¼" line is required. The unit requires clean dry air.
2. Connect the foot switch or finger switch to the rear dispenser control box.
3. Plug the power cord into the rear of the Dispenser. Then plug the 3 prong end into a grounded 110 VAC outlet.
4. Fill the syringe with the material you want to dispense. Install a syringe stopper and then insert and twist the adapter head onto the syringe.
5. Connect the tubing from the Adapter Assembly to the Dispenser using the quick disconnect fitting provided.

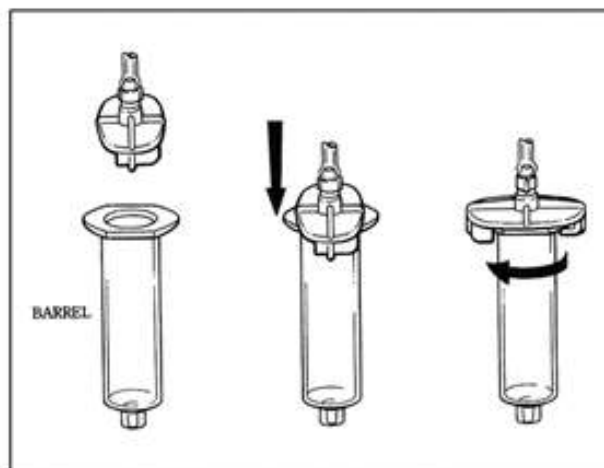

OPERATION

1. Turn the dispenser's power on by using the switch on the front.
2. The large round knob on the front control panel controls the pressure to the cartridge. Turning the knob clockwise will increase the pressure. The pressure can be read from the gauge on the front panel.
3. The dispense time is adjusted by using timer buttons in the center of the dispenser. The timer is adjustable from 0.001 to 9.999 seconds.
4. When the timer is set to 0.000, the applicator will dispense as long as the foot switch or finger switch is pressed. The display will count the amount of time until the foot switch or finger switch is released. This feature can be used to determine a timer setting by experimentation.
5. The Model 615 has a vacuum pullback feature. This feature allows you to dispense very low viscosity materials. The vacuum adjustable knob is on the front center of the dispenser. Turning this knob Counterclockwise will increase the amount of vacuum.

HOW TO USE THE VACUUM CONTROL

1. Place the dispenser about 12 inches above the workbench. This will prevent any drawback of liquid into the vacuum transducer. The vacuum transducer can be damaged if the material being dispensed flows through the hose into the unit.
2. Turn the vacuum control off (clockwise) before proceeding.
3. Attach the safety clip to the hose and close it on the hose.
4. Set the air pressure between 2 and 5 PSI.
5. Attach the cartridge to the adapter assembly.
6. Release the safety clip. The material in the cartridge may begin to drip out. CAREFULLY AND SLOWLY, turn the knob for the vacuum control counter-clockwise until you see a slight bubbling. Then slowly decrease the vacuum until the bubbling stops. You want to achieve a balance, so that the material doesn't drip and it doesn't bubble.
7. DO NOT TIP THE CARTRIDGE UPSIDE DOWN OR LAY FLAT. ALWAYS REPLACE CARTRIDGE BACK IN THE STAND AFTER USE.

TIPS ON DISPENSING

1. The Cartridge should be held at a 60-degree angle to work surface. The tip should contact the work surface for more consistent deposits. See Fig. 1.
2. Dot size is affected by three factors: Needle size, pressure setting and the time the foot switch is depressed. Small needle sizes, shorter timing cycles and lower pressure will each reduce the size of the deposit.
3. After making the deposit, lift the tip as shown in Fig.2

4. Start with the air pressure of 10-15 PSI. Most materials can easily be dispensed at this pressure.
5. If you are working on a component in which the metal tip could damage the piece, press a Teflon sleeve over the needle allowing it to slightly protrude past the tip.
6. Keep the dispenser clean. Always use clean cartridges and tips to ensure cleanliness and prevent contamination.
7. Do not lay a filled syringe on its side and permit the liquid to flow back into the controller. See Fig. 3

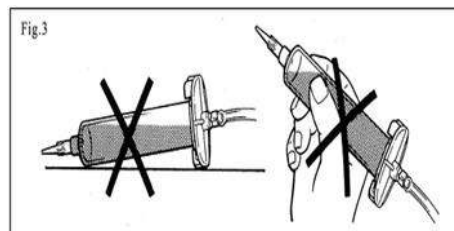
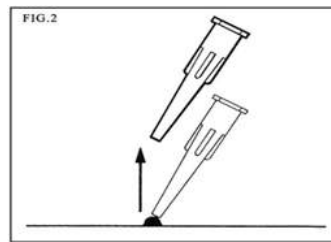
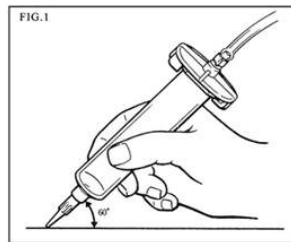

SELECTING THE CORRECT TIP SIZE

The tip size depends on two things: the particle size of the material to be dispensed and the amount you want to dispense. When determining the time and pressure settings, it is best to use the largest tip possible and keep the time setting as short as possible.

There are 12 different Stainless Steel tip sizes to suit all types of materials. Your startup kit includes a sampling of 6 of those 12 needles we carry. We also carry an assortment of poly free flow tips.

Gage	Size	Color
14	.063	White
15	.054	Brown
16	.047	Dark Purple
18	.033	Dark Green
19	.027	Light Green
20	.023	Pink

Gage	Size	Color
21	.020	Medium Purple
22	.016	Blue
23	.013	Orange
25	.010	Red
27	.008	Lavender
30	.007	Light Grey

WHAT CAN I DISPENSE?

1. Solder and Brazing pastes-all types can be dispensed. Vacuum pullback should not be used for soldering and brazing pastes because it can cause separation.
2. Lubricants – Thick grease and oils.
3. Epoxies – One or two part epoxies can be used. If two part epoxies are used, remember that the viscosity changes with time and the pressure will have to be adjusted to compensate.
4. Cyanoacrylates – A filter should be used prevent the instant adhesives from running back into the dispenser. These materials can permanently damage your dispenser. The filter can be easily installed by cutting the adapter hose about 12” from the quick-disconnect fitting and pressing both ends into the filter.
5. Anaerobics – Use similar precautions as for Cyanoacrylates.
6. Solder Mask/Solder Resist – If solvent evaporation is a problem, then an inert gas such as nitrogen can be used in place of compressed air.
7. Acrylics.

Accessories included with the 615 Dispenser	
Description	Quantity(pcs)
Power Cord	1
Foot Switch	1
Finger Switch	1
Air Hose	1
Syringe Stand	1
Operating Manual	1

LIMITED WARRANTY

Manufacturer warrants this product to the original purchaser for a period of two (1) year from date of purchase to be free of defects in material and workmanship, but not against damages by misuse, negligence, accident, faulty installation, abrasion, corrosion, or by "not" operating in accordance with factory recommendations and instructions. Manufacturer will repair or replace (at factory's option), free of charge, any component of the equipment thus found to be defective, on return to the factory during the warranty period. In no event shall any liability or obligation of manufacturer arising from this warranty exceed the purchase price of the equipment. This warranty is valid only when 5 micron filtered air is used. The manufacturer's liability stated herein, cannot be altered or enlarged except by a written statement signed by a company officer. In no event shall manufacturer be liable for consequential or incidental damages.